

STORINGSLIJST PAC

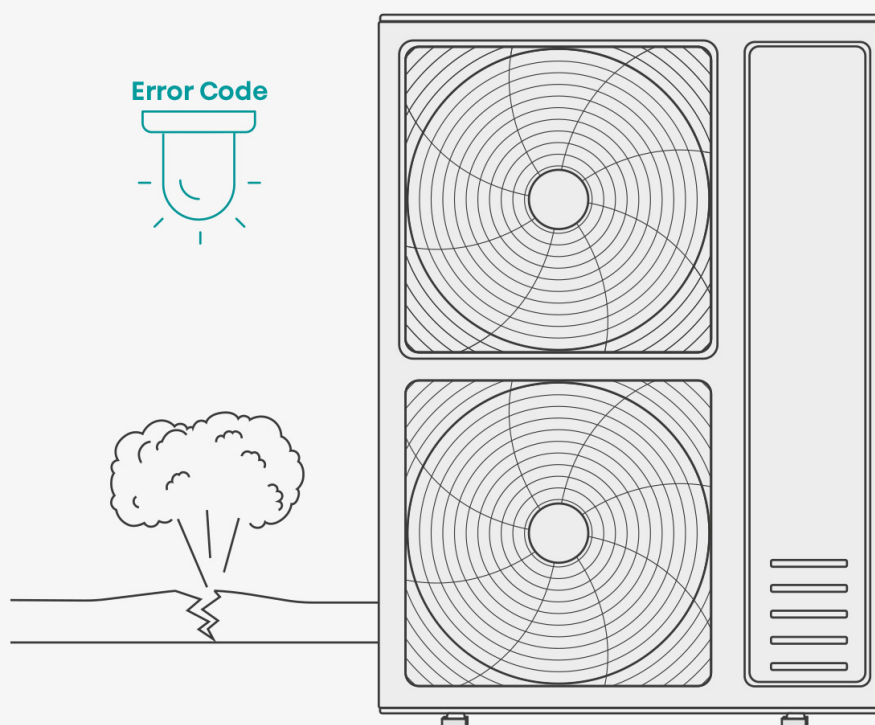

Bij de PAC serie van Hisense, worden efficiënte lucht/lucht warmtepompen aangeboden voor uw kantoor of praktijkruimte. Met koelvermogens variërend van 2,6 kW tot 25,0 kW en verwarmingsvermogens tussen 2,7 kW en 20,0 kW, voldoen deze systemen aan de behoefte aan groot vermogen gedurende het hele jaar. Hisense staat garant voor een duurzaam en efficiënt lucht/lucht warmtepompsysteem dankzij het gebruik van geavanceerde technologieën.

Een kenmerk van onze systemen is de mogelijkheid om meerdere binnendelen van het cassette-type aan te sluiten op slechts één buitendeel, dankzij het huidige dataprotocol. Dit biedt flexibiliteit en optimaliseert de installatie voor diverse ruimtes. Voor het type kanaal-, vloer- en plafondmodel zal deze mogelijkheid in een later stadium beschikbaar zijn.

Om ervoor te zorgen dat deze optimaal blijft functioneren, is het belangrijk om op de hoogte te zijn van mogelijke storingscodes en de bijbehorende oplossingen. Houd deze lijst binnen handbereik voor snelle referentie. Mocht u onverhoopt een storing tegenkomen die niet in deze lijst staat, neem dan contact op met onze serviceafdeling voor professionele ondersteuning.



16. Troubleshooting

16.1 Trouble guide Troubleshooting for normal malfunction

Troubleshooting	Possible Reasons of Abnormality	How to Deal With
Air conditioner can not start up	<ol style="list-style-type: none"> 1. Power supply failure; 2. Trip of breaker or blow of fuse ; 3. Power voltage is too low; 4. Improper setting of remote controller; 5. Remote controller is short of power. 	<ol style="list-style-type: none"> 1. Check power supply circuit; 2. Measure insulation resistance to ground to see if there is any leakage; 3. Check if there is a defective contact or leak current in the power supply circuit; 4. Check and set remote controller again; 5. Change batteries.
The compressor starts or stops frequently	The airinlet and outlet have been blocked.	Remove obstacles.
Poor cooling/heating	<ol style="list-style-type: none"> 1. The outdoor heat exchanger is dirty, such as condenser; 2. There are heating devices indoors; 3. The airtightness is not enough, and people come in and out too frequently; 4. Block of outdoor heate xchanger; 5. Improper setting of temperature. 	<ol style="list-style-type: none"> 1. Clean the heat exchanger of the outdoor unit, such as condenser; 2. Remove heating devices; 3. Keep certain air tightness indoors; 4. Remove block obstacles; 5. Check and try to set temperature again.
Sound from deforming parts	During system starting or stopping, a sound might be heard. However, this is due to the normal deformation of plastic parts.	It is not abnormal, and the sound will disappear soon.
Waterleakage	<ol style="list-style-type: none"> 1. Drainage pipe is blocked or broken; 2. Wrap of refrigerant pipe joint is not closed completely. 	<ol style="list-style-type: none"> 1. Change drainage pipe; 2. Re-wrap and make it tight.

Troubleshooting according to fault codes

When the air conditioner failure occurs, the fault code will display on control board, wired controller or display panel.

How to check fault codes

Indoor unit

(1) Fault codes indicated by wired controller

MODEL:YXE-C01U1(E)

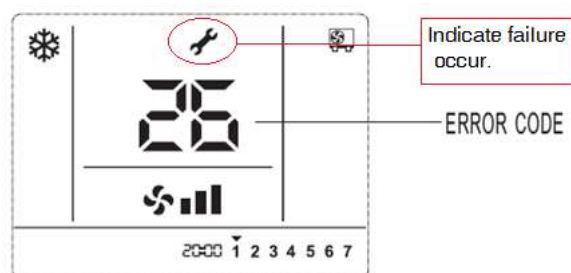

When the airconditioner is malfunction,  will display on the LCD, and error codes will appear and blink.

Fault code displays on wired controller

MODEL: YXE-E01U(E)

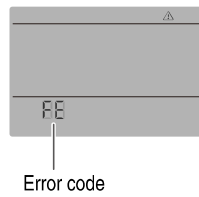

When the air conditioner malfunctions,  will be displayed on the LCD, indicating that error is occurring, please consult your local dealer or after-sales service.

Fault code displays on wired controller

(2) Fault codes indicated by display panel

Display panel

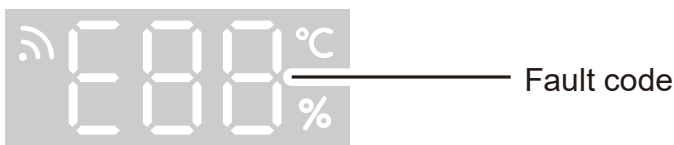

(3) Fault codes indicated by LED lamps on display panel

Lamp RUN (LED2, Red) and Lamp DEFROST (LED5, Green) flash. Lamp RUN displays fault code represented by 2- digit number, and lamp DEFROST displays fault code represented by single digit number (as shown fig. below). For example, fault code 36: LED RUN & defrost flash 3 times at the same time, and LED DEFROST continues flashing 3 times, it reports No. 36 fault.

Display panel

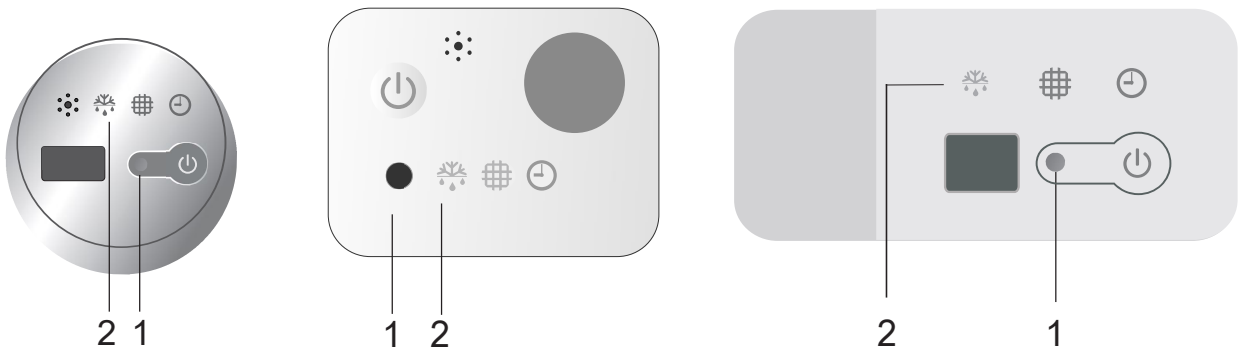

- 1 Run indicator (Red)
Indicates the fault code with 2- digit number.
- 2 Defrost indicator (Green)
Indicates the fault code with single digit number.

LED FLASH CONTROL: flash 300mS (T1), off 300mS (T2), after 2000mS (T3) fault code repeat displays. (as shown below)

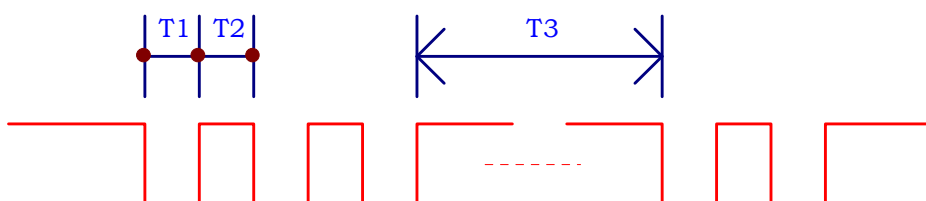

FIG.2 LED flash control

36K~48K (Fault code displayed by LED lamps on outdoor main control board.)

Fault code displayed by LED lamps on outdoor main control board.

There are 3 LED lamps on control board, V19, V20 and V21.

V19 indicates the ten's place of the fault code, V20 indicates the unit's place of the fault code and V21 indicates outdoor drive control fault.

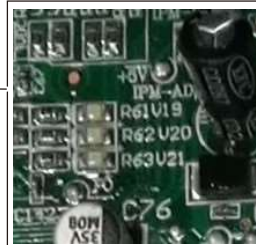

Main control failure indicator:
V19: Ten's Place
V20: Unit's Place

Drive failure indicator: V21

Outdoor unit

Fault code displayed on checker board

Fault code/drive fault code will be displayed on checker board.

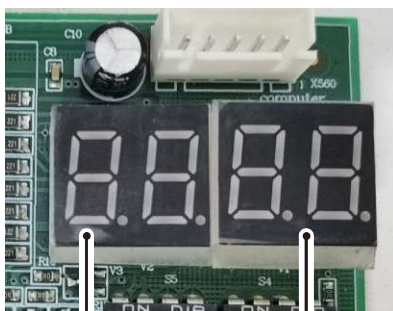
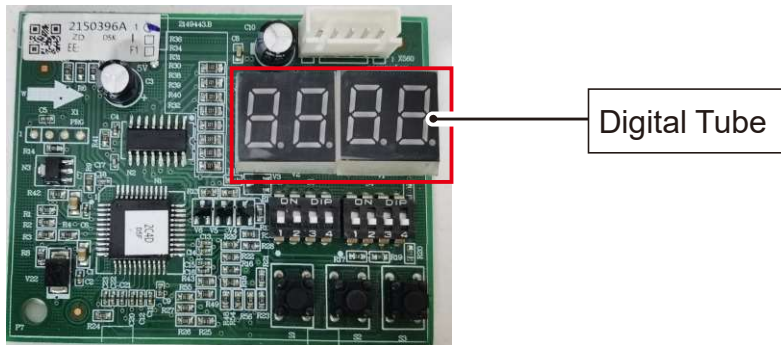

E shows failure occur

Display ERROR code

16.2 Fault codes

Table 1 Outdoor fault code

Fault code	Fault description	Possible reasons for abnormality	How to deal with	Remarks
1	Outdoor ambient temperature sensor fault	<ol style="list-style-type: none"> 1.The outdoor ambient temperature sensor is connected loosely; 2.The outdoor ambient temperature sensor fails to work; 3.The sampling circuit fails. 	<ol style="list-style-type: none"> 1.Reconnect the outdoor ambient temperature sensor; 2.Replace the outdoor ambient temperature sensor components; 3.Replace the outdoor control board components. 	
2	Outdoor coil temperature sensor fault	<ol style="list-style-type: none"> 1.The outdoor coil temperature sensor is connected loosely; 2.The outdoor coil temperature sensor fails to work; 3.The sampling circuit fails. 	<ol style="list-style-type: none"> 1.Reconnect the outdoor coil temperature sensor; 2.Replace the outdoor coil temperature sensor components; 3.Replace the outdoor control board components. 	
3	The unit over-current turn off fault	<ol style="list-style-type: none"> 1. Control board current sampling circuit fails; 2. The current is over high because the supply voltage is too low; 3. The compressor is blocked; 4. Overload in cooling mode; 5. Overload in heating mode. 	<ol style="list-style-type: none"> 1. Replace the electrical control board components; 2. Normal protection; 3. Replace the compressor; 4. Please see NOTE 3; 5. Please see NOTE 4. 	
4	EEprom Data error	<ol style="list-style-type: none"> 1.EE components fails; 2.EE components control circuit fails; 3.EE components are inserted incorrectly. 	<ol style="list-style-type: none"> 1.Replace the EE components; 2.Replace the outdoor control board components; 3.Reassemble the EE components. 	
5	Cooling freezing protection (the indoor coil temperature is too low) or heating overload (indoor coil temperature is too high)	<ol style="list-style-type: none"> 1.The indoor unit can not blow air normally; 2.The room temperature is too low in cooling mode or the room temperature is too high in heating; 3.The filter is dirty; 4.The duct resistance is too high to result in low air flow; 5.The setting fan speed is too low; 6.The indoor unit is not installed in accordance with the installation standards, and the air inlet is too close to the air outlet . 	<ol style="list-style-type: none"> 1.Check whether the indoor fan, indoor fan motor and evaporator work normally; 2.Normal protection; 3.Clean the filter; 4.Check the volume control valve, duct length etc.; 5.Set the speed with high speed; 6.Reinstall the indoor unit referring to the user manual to change the distance between the indoor unit and the wall or ceiling. 	
7	The communication fault between the indoor unit and outdoor unit	<ol style="list-style-type: none"> 1.The connection cable is connected improperly between the indoor unit and outdoor unit; 2.The communication cable is connected loosely; 3.The communication cable fails; 4.The indoor control board fails; 5.The outdoor control board fails; 6.Communication circuit fuse open; 7.The specification of communication cable is incorrect. 	<ol style="list-style-type: none"> 1.Reconnect the connection cable referring to the wiring diagram; 2.Reconnect the communication cable; 3.Replace the communication cable; 4.Replace the indoor control board; 5.Replace the outdoor control board; 6.Check the communication circuit, adjust the DIP switch and the short-circuit fuse. 7.Choose suitable communication cable referring to the user manual 	

Fault code	Fault description	Possible reasons for abnormality	How to deal with	Remarks
12	Voltage absent phase	Three-phase power is abnormal; The outdoor wiring is connected improperly; The outdoor control board fails.	1. Normal protection; 2. Check the wiring connection referring to the wiring diagram; 3. Replace the outdoor control board.	Application of three-phase power supply models
13	Compressor overheat protector device	1. The wiring of the overload protector is connected loosely; 2. The overload protector fails; 3. The refrigerant is not enough; 4. The installation pipe is much longer than the normal one, but no extra refrigerant is added; 5. The expansion valve fails; 6. The outdoor control board fails.	1. Reconnect the wiring of the overload protector; 2. Replace the overload protector; 3. Check the welding point of the unit to confirm whether there is leakage, and then recharge the refrigerant; 4. Add the refrigerant; 5. Replace expansion valve; 6. Replace the outdoor control board.	
14	The high pressure switch operation or the unit is turned off for high pressure protection	1. The wiring of the high pressure protector is connected loosely; 2. The high pressure protector fails; 3. The outdoor control board is abnormal; 4. Overload in cooling; 5. Overload in heating.	1. Reconnect the wiring of the high pressure protector; 2. Replace the high pressure protector; 3. Replace the outdoor control board; 4. Please refer to NOTE 3; 5. Please refer to NOTE 4.	Applied to models with high pressure switch or pressure sensor
15	The low pressure switch protection or the unit is turned off for low pressure protection	1. The wiring of the low pressure switch is connected loosely; 2. The low pressure switch fails; 3. The refrigerant is not enough; 4. The expansion valve fails in heating mode; 5. The outdoor control board is abnormal.	1. Reconnect the wiring of the low pressure switch; 2. Replace the low pressure switch; 3. Check the welding point to confirm whether the unit leaks, and then add some refrigerant; 4. Replace the expansion valve; 5. Replace the outdoor control board.	Applied to models with low pressure switch or pressure sensor
16	Overload protection in cooling mode	System overloads.	Please refer to NOTE 3.	
17	Discharge temperature sensor fault	1. The wiring of the discharge temperature sensor is connected loosely; 2. The discharge temperature sensor fails; 3. The sampling circuit is abnormal.	1. Reconnect the wiring of the discharge temperature sensor; 2. Replace the discharge temperature sensor; 3. Replace the outdoor control board.	
18	AC voltage is abnormal	1. The AC voltage >275V or <160V; 2. The AC voltage of sampling circuit on the driver board is abnormal.	1. Normal protection, please check the supply power; 2. Replace the driver board.	
19	Suction temperature sensor fault	1. The wiring of the suction temperature sensor is connected loosely; 2. The suction temperature sensor fails; 3. The sampling circuit is abnormal.	1. Reconnect the wiring of the suction temperature sensor; 2. Replace the suction temperature sensor; 3. Replace the outdoor control board.	
22	The defrosting sensor fault	1. The wiring of the defrosting sensor is connected loosely; 2. The defrosting sensor fails; 3. The sampling circuit is abnormal.	1. Reconnect the wiring of the defrosting sensor; 2. Replace the defrosting sensor; 3. Replace the outdoor control board.	
45	IPM fault	There are many reasons for this failure. You can check the driver board fault LED to further analyze the fault code of the drive board and to learn about what leads to the fault and how to operate it. Specific information can be seen in table 4, table 5.	See attached "analysis of the driving board fault".	

Fault code	Fault description	Possible reasons for abnormality	How to deal with	Remarks
46	IPM and control board communication fault	<ol style="list-style-type: none"> 1.The cable between the control board and the driver board is connected loosely; 2.The cable between the control board and the driver board fails; 3.The driver board fails; 4.The control board fails. 	<ol style="list-style-type: none"> 1.Reconnect the cable between the control board and the driver board; 2.Replace the communication cable between the control board and the driver board; 3.Replace the driver board; 4.Replace the control board. 	
47	Too high discharge temperature fault	<ol style="list-style-type: none"> 1. The refrigerant of the unit is not enough; 2.The refrigerant of the unit is not enough due to that the installation pipe is longer; 3.Throttling service fails; 4.The outdoor ambient temperature is too high. 	<ol style="list-style-type: none"> 1.Check the welding point to confirm whether the unit has leakage point, and then add some refrigerant; 2. Add some refrigerant referring to the installation user manual; 3. Replace the throttling service (such as capillary, expansion valve); 4.Normal protection. 	
48	The outdoor DC fan motor fault (upper fan motor)	<ol style="list-style-type: none"> 1.The connecting wiring of the up DC fan motor is loose; 2.The cord of the upper DC fan motor fails; 3.The upper DC fan motor fails; 4.The drive circuit of the upper DC fan motor fails; 5.The outdoor fan has been blocked. 	<ol style="list-style-type: none"> 1.Reconnect the wiring of the up DC fan motor; 2.Replace the upper DC fan motor; 3.Replace the upper DC fan motor; 4.Replace the driver board of the fan motor; 5.Check the outdoor fan and ensure the outdoor fan can run normally. 	
49	The outdoor DC fan motor fault (down fan motor)	<ol style="list-style-type: none"> 1.The connecting wiring of the down DC fan motor is loose; 2.The cord of the down DC fan motor fails; 3. The down DC fan motor fails; 4. The drive circuit of the down DC fan motor fails; 5. The outdoor fan has been blocked. 	<ol style="list-style-type: none"> 1. Reconnect the wiring of the down DC fan motor; 2. Replace the down DC fan motor; 3. Replace the down DC fan motor; 4. Replace the driver board of the fan motor; 5. Check the outdoor fan and ensure the outdoor fan can run normally. 	
91	The unit is turned off due to the IPM board over heating fault	<ol style="list-style-type: none"> 1.The outdoor ambient temp. is too high; 2.The speed of the out fan motor is too low if the fan motor is AC fan motor; 3.The outdoor unit is not installed in accordance with the standard; 4.The supply power is too low. 	<ol style="list-style-type: none"> 1. Normal protection; 2. Check the fan capacitor, and replace the fan capacitor if it fails; 3. Reinstall the outdoor unit referring to the installation user manual; 4.Normal protection. 	
96	Lacking of refrigerant	The refrigerant of the unit is not enough.	Discharge the refrigerant and charge the refrigerant referring to the rating label.	
97	4-way valve commutation failure fault	<ol style="list-style-type: none"> 1.The connecting wiring of the 4-way valve coil is loose; 2.The 4-way valve coil fails; 3.The 4-way valve fails; 4.The driver board of the 4-way valve fails. 	<ol style="list-style-type: none"> 1. Reconnect the wiring of the 4-way valve; 2. Replace the 4-way valve coil; 3. Replace the 4-way valve; 4.Replace the driver board of the 4-way valve. 	

The following is the fault code table of indoor unit.

Table 2 Indoor fault code

Fault code	Fault description	Possible reasons for abnormality	How to deal with	Remarks
37	Humidity sensor failure	<ol style="list-style-type: none"> 1.The cable of the humidity sensor connect loose; 2.The humidity sensor is failure; 3.The indoor control board is failure. 	<ol style="list-style-type: none"> 1. Reconnect the cable of the humidity sensor; 2. Replace the humidity sensor; 3.Replace the indoor control board. 	
51	Drainage protection	<ol style="list-style-type: none"> 1. The water level of the drain pan exceeds safe level; 2. The cable of the water level switch is connected loosely; 3.The water level switch fails; 4.The control board fails. 	<ol style="list-style-type: none"> 1. Check whether there is something blocking the drain hose or the height of the drain hose is too high; 2. Check the water pump and replace the water pump if the water pump fails; 3. Reconnect the cable of the water level switch referring to the wiring diagram; 4. Replace the water level switch; 5. Replace the control board. 	
55	Mode conflict fault	The user sets the conflicting mode for more than two indoor units.	Reset the operation mode for the indoor unit, for with one outdoor unit, the user should avoid setting the conflicting operation mode with the indoor units.	
64	Communication between Indoor & Outdoor unit Fault	<ol style="list-style-type: none"> 1. The indoor unit and the outdoor unit are not connected properly; 2. The communication cable is connected loosely; 3. The communication cable between the indoor unit and the outdoor unit fails or the cable between the indoor control board to terminal fails or the cable between the outdoor control board to the terminal fails; 4. The indoor control board fails; 5. The outdoor control board fails. 	<ol style="list-style-type: none"> 1. Reconnect the connection cable referring to the indoor and outdoor wiring diagram; 2. Reconnect the communication cable referring to the indoor and outdoor wiring diagram; 3. Replace the communication cable referring to the indoor and outdoor wiring diagram; 4. Replace the indoor control board; 5. Replace the outdoor control board. 	

Fault code	Fault description	Possible reasons for abnormality	How to deal with	Remarks
72	Indoor fan motor fault	<ol style="list-style-type: none"> 1. The cable of the indoor fan motor is connected loosely; 2. The cable of the indoor fan motor fails; 3. The indoor fan motor fails; 4. The indoor control board fails. 	<ol style="list-style-type: none"> 1.Reconnect the cable of the fan motor; 2.Replace the cable of the fan motor; 3.Replace the fan motor; 4.Replace the indoor control board; 5.Check the indoor fan and ensure the indoor fan can run normally. 	
73	Indoor EEPROM Data 1 fault	<ol style="list-style-type: none"> 1. Indoor EE components fail; 2. The control circuit of the EE components fails; 3. The EE components has been inserted in opposite direction. 	<ol style="list-style-type: none"> 1. Replace the EE components; 2. Replace the indoor control board; 3. Reassemble the EE components of the indoor control board. 	
81	Indoor ambient Temperature Sensor Fault	<ol style="list-style-type: none"> 1. The cable of the room temperature sensor is connected loosely; 2. The room temperature sensor fails; 3. The sampling circuit is abnormal. 	<ol style="list-style-type: none"> 1. Reconnect the cable of the room temperature sensor; 2. Replace the room temperature sensor; 3. Replace the indoor control board. 	
83	Evaporator Middle Temperature Sensor Fault	<ol style="list-style-type: none"> 1.The cable of the coil temperature sensor of the evaporator fails; 2.The coil temperature sensor of the evaporator fails; 3.The sampling circuit is abnormal. 	<ol style="list-style-type: none"> 1. Reconnect the cable of the coil temperature sensor of the evaporator; 2. Replace the coil temperature sensor of the evaporator; 3. Replace the indoor control board. 	
FE (254)	Communication between main control board & Wired controller Fault (display on wired controller)	<ol style="list-style-type: none"> 1. The wired controller and the indoor control board are connected loosely; 2. The sequence of the wiring between the wired controller to the indoor control board is wrong; 3. The wiring between the wired controller to the indoor control board fails; 4. The wired controller fails; 5. The indoor control board is abnormal. 	<ol style="list-style-type: none"> 1. Reconnect the wiring between the wired controller to the indoor control board; 2. Replace the wiring between the wired controller to the indoor control board; 3. Replace the wiring between the wired controller to the indoor control board; 4. Replace the wired controller; 5. Replace the indoor control Board. 	
ER	Communication between main control board & display board Fault (displays on display board)	<ol style="list-style-type: none"> 1.The wiring between the display board to the indoor control board is connected loosely; 2.The sequence of the wiring between the display board to the indoor control board is wrong; 3.The wiring between the display board to the indoor control board fails; 4.The display board fails; 5.The indoor control board fails. 	<ol style="list-style-type: none"> 1. Reconnect the wiring between the display board to the indoor control board; 2. Replace the wiring between the display board to the indoor control board; 3. Replace the wiring between the display board to the indoor control board; 4. Replace the display board; 5. Replace the indoor control board. 	

NOTE 1:

If the indoor unit can not start or the indoor unit stops itself after 30s, at the same time the unit do not display the fault code, please check the fire and the socket of the control board.

NOTE 2:

If the indoor unit displays the 75,76,77,78 fault code after you turn on the unit, please check the TEST seat of the indoor control board or the TEST detection circuit to see whether short circuit occurs.

NOTE 3: Overload in cooling mode

Overload in cooling mode		
sr.	The root cause	Corrective measure
1	The refrigerant is excessive.	Discharge the refrigerant, and recharge the refrigerant referring to the rating label.
2	The outdoor ambient temperature is too high.	Please use it within allowable temperature range
3	Short-circuit occurs in the air outlet and air inlet of the outdoor unit.	Adjust the installation of the outdoor unit referring to the user manual.
4	The outdoor heat exchanger is dirty, such as condenser.	Clean the heat exchanger of the outdoor unit, such as condenser.
5	The speed of the outdoor fan motor is too low.	Check the outdoor fan motor and fan capacitor.
6	The outdoor fan is broken or the outdoor fan is blocked.	Check the outdoor fan.
7	The air inlet and outlet have been blocked.	Remove the obstacles.
8	The expansion valve or the capillary fails.	Replace the expansion valve or the capillary.

NOTE 4: Over load in heating mode

Overload in heating mode		
sr.	The root cause	Corrective measure
1	The refrigerant is excessive.	Discharge the refrigerant, and recharge the refrigerant referring to the rating label.
2	The indoor ambient temperature is too high.	Please use within allowable temperature range.
3	Short-circuit occurs in the air outlet and air inlet of the indoor unit.	Adjust the installation of the indoor unit referring to the user manual.
4	The indoor filter is dirty.	Clean the indoor filter.
5	The speed of the indoor fan motor is too low.	Check the indoor fan motor and fan capacitor.
6	The indoor fan is broken or the outdoor fan is blocked.	Check the indoor fan.
7	The air inlet and outlet have been blocked.	Remove the obstacles.
8	The expansion valve or the capillary fails.	Replace the expansion valve or the capillary.

Table 3 Analysis of the driving board fault (14K~24K)

Fault code	Fault description	Possible reasons for abnormality	How to deal with
1	Inverter DC voltage overload fault	1. Power supply input is too high or too low; 2. Driver board fault.	1. Check power supply ; 2. Change driver board.
2	Inverter DC low voltage fault		
3	Inverter AC current overload fault		
4	Out-of-step detection	1. Compressor phase lost ; 2. Bad driver board components ; 3. The compressor insulation fault.	1. Check compressor wire connection; 2. Change the driver board; 3. Change compressor.
5	Loss phase detection fault (speed pulsation)		
6	Loss phase detection fault (current imbalance)		
7	Inverter IPM fault (edge)	1. System overload or current overload; 2. Driver board fault. 3. Compressor oil shortage, serious wear of crankshaft ; 4. The compressor insulation fault.	1. Check the system. 2. Change the driver board; 3. Change the compressor; 4. Change the compressor.
8	Inverter IPM fault (level)		
9	PFC_IPM IPM fault (edge)		
10	PFC_IPM IPM fault (level)		
11	PFC power detection of failure	1. The power supply is not stable; 2. Instantaneous power off; 3. Driver board failure.	1. Check the power supply. 2. No need to deal with. 3. Change the driver board.
12	PFC overload current detection of failure.	1. System overload, current is too high; 2. Driver board fails; 3. PFC fails.	1.Check the system; 2.Change the driver board; 3.Change the PFC.
13	DC voltage detected abnormal .	1. Input voltage is too high or too low; 2. Driver board fails.	1. Check the power supply; 2. Change the driver board.
14	PFC LOW voltage detected failure.		
15	AD offset abnormal detected failure.	Driver board fails.	Change the driver board.
16	Inverter PWM logic set fault.		
17	Inverter PWM initialization failure		
18	PFC_PWM logic set fault.		
19	PFC_PWM initialization fault.		
20	Temperature abnormal.		
21	Shunt resistance unbalance adjustment fault		
22	Communication failure.	1. Communication wire connection is not proper; 2. Driver board fails; 3. Control board fails.	1. Check the wiring; 2. Change the driver board; 3. Change the control board.
23	Motor parameters setting of failure	Initialization is abnormal.	Reset the power supply.
25	EE data abnormal	Driver board EEPROM is abnormal	1. Change EEPROM ; 2. Change the driver board.
26	DC voltage mutation error	1. Power input changes suddenly 2. Driver board fails.	1.Check power supply, to provide stable power supply; 2.Change driver board.
27	D axis current control error	1. System overload, phase current is too high; 2. Driver board fails.	1. Check system to see if it works normally. 2. Check stop valve to see if it is open; 3. Change the driver board.
28	Q axis current control error	1. System overloads, phase current is too high ; 2. Driver board fails.	1. Check system to see if it works normally. 2. Check stop valve to see if it is open; 3. Change the driver board.
29	Saturation error of d axis current control integral	1. System overload suddenly; 2. Compressor parameter is not suitable; 3. Driver board fails.	1. Check system to see if it works normally. 2. Check stop valve to see if it is open; 3. Change the driver board.
30	Saturation error of q axis current control integral	1. System overload suddenly; 2. Compressor parameter is not suitable; 3. Driver board fails.	1. Check system to see if it works normally. 2. Check stop valve to see if it is open; 3. Change the driver board.

Fault code	Fault description	Possible reasons for abnormality	How to deal with
50	Inverter software over-current	<ol style="list-style-type: none"> 1. The fan motor system overloads; 2. The drive board fails; 3. The fan motor is not insulated well; 	<ol style="list-style-type: none"> 1. Change the fan motor; 2. Change the drive board; 3. Change the fan motor.
51	Out-of-step detection	<ol style="list-style-type: none"> 1. The wire is not connected well; 2. Bad drive board components; 3. The fan motor starting overloads; 4. The fan motor is demagnetized; 5. The fan motor is not insulated well. 	<ol style="list-style-type: none"> 1. Check the fan motor wire connection; 2. Change the drive board; 3. Change the fan motor. 4. Change the fan motor. 5. Change the fan motor.
52	Abnormal speed control	<ol style="list-style-type: none"> 1. Bad driver board components; 2. The fan motor shaft clamping; 3. The fan motor insulation fails. 	<ol style="list-style-type: none"> 1. Change the drive board; 2. Change the fan motor. 3. Change the fan motor.
53	Out of phase detection fault	<ol style="list-style-type: none"> 1. Phase loss of the fan motor; 2. Bad drive board components. 	<ol style="list-style-type: none"> 1. Change the drive board; 2. Change the fan motor; 3. Change the fan motor
54	IPM-FO hardware over-current (edge)	<ol style="list-style-type: none"> 1. The fan motor overloads or over-current; 2. The drive board fails; 3. The fan motor insulation fails. 	<ol style="list-style-type: none"> 1. Change the fan motor; 2. Change the drive board; 3. Change the fan motor
55	IPM-FO hardware over-current (level)	<ol style="list-style-type: none"> 1. The fan motor overloads or over-current; 2. The drive board fails; 3. The fan motor insulation fails. 	<ol style="list-style-type: none"> 1. Change the fan motor; 2. Change the drive board; 3. Change the fan motor
56	The fan motor -AD Offset abnormal detection fault	The drive board circuit fails.	Change the drive board.
57	The fan motor speed control integral saturation	<ol style="list-style-type: none"> 1. The fan motor overload mutation; 2. Parameters are inappropriate; 3. The drive board fault. 	<ol style="list-style-type: none"> 1. Change the fan motor system; 2. Change the fan motor; 3. Change the drive board.
58	The fan motor D,Q axis current control error	<ol style="list-style-type: none"> 1. The fan motor overloads, the phase current is large; 2. The drive board fault. 	<ol style="list-style-type: none"> 1. Check the fan motor system; 2. Change the drive board.
59	The fan motor D,Q axis current control integral saturation	<ol style="list-style-type: none"> 1. The fan motor overload mutation; 2. Parameters are inappropriate; 3. The drive board fault. 	<ol style="list-style-type: none"> 1. Change the fan motor system; 2. Change the fan motor; 3. Change the drive board.
60	The fan motor reverse	<ol style="list-style-type: none"> 1. Bad drive board components; 2. Wiring problems 	<ol style="list-style-type: none"> 1. Change the drive board; 2. Check the wiring.
61	IPM-PWM initialization fault	<ol style="list-style-type: none"> 1. EE logics error; 2. The drive board fails. 	<ol style="list-style-type: none"> 1. Change the drive board; 2. Change the drive board.

Table 4 Analysis of the driving board fault (36K~48K)

Fault code	Fault description	Possible reasons for abnormality	How to deal with		
1	Inverter DC voltage overload fault	1. Power supply input is too high or too low; 2. Driver board fault.	1. Check the power supply; 2. Change the driver board.		
2	Inverter DC low voltage fault				
3	Inverter AC current overload fault				
4	Out-of-step detection	1. Compressor phase lost; 2. Bad driver board components; 3. The compressor insulation fault.	1. Check the compressor wire connection; 2. Change the driver board; 3. Change the compressor.		
5	Loss phase detection fault (speed pulsation)				
6	Loss phase detection fault (current imbalance)				
7	Inverter IPM fault (edge)	1. System overload or current overload; 2. Driver board fault; 3. Compressor oil shortage, serious wear of crankshaft ; 4. The compressor insulation fault.	1. Check the system; 2. Change the driver board; 3. Change the compressor; 4. Change the compressor.		
8	Inverter IPM fault (level)				
9	PFC fault (edge)				
10	PFC fault (level)				
11	PFC power detection of failure	1. The power supply is not stable; 2. Instantaneous power failure; 3. Driver board failure.	1. Check the power supply; 2. No need to deal with; 3. Change the driver board.		
12	PFC overload current detection of failure.	1. System overloads, and the current is too high; 2. Driver board fails; 3. PFC fails.	1. Check the system; 2. Change the driver board; 3. Change the PFC.		
13	DC voltage detected abnormal .	1. Input voltage is too high or too low; 2. Driver board fails.	1. Check the power supply; 2. Change the driver board.		
14	PFC LOW voltage detected failure.				
15	AD offset abnormal detected failure.				
16	Inverter PWM logic set fault.				
17	Inverter PWM initialization failure				
18	PFC_PWM logic set fault.				
19	PFC_PWM initialization fault.				
20	Temperature abnormal.				
21	Shunt resistance unbalance adjustment fault	Driver board fails.	Change the driver board.		
22	Communication failure.				
23	Motor parameters setting of failure			1. Communication wire connection is not proper; 2. Driver board fails; 3. Control board fails.	1. Check the wiring; 2. Change the driver board; 3. Change the control board.
25	EE data abnormal			Initialization is abnormal.	Reset the power supply.
26	DC voltage mutation error			1. Power input changes suddenly; 2. Driver board fails.	1. Change EEPROM; 2. Change the driver board.
27	D axis current control error			1. System overload, phase current is too high; 2. Driver board fails.	1. Check the power supply, to provide stable power supply; 2. Change the driver board.
28	Q axis current control error			1. System overload, phase current is too high; 2. Driver board fails.	1. Check if the system is normal; 2. Check if the stop valve is open; 3. Change the driver board.
29	Saturation error of D axis current control integral	1. System overloads suddenly; 2. Compressor parameter is not suitable; 3. Driver board fails.	1. Check if the system is normal; 2. Check if the stop valve is open; 3. Change the driver board.		
30	Saturation error of Q axis current control integral	1. System overloads suddenly; 2. Compressor parameter is not suitable; 3. Driver board fails.	1. Check if the system is normal; 2. Check if the stop valve is open; 3. Change the driver board.		

Fault code	Fault description	Possible reasons for abnormality	How to deal with
50	Inverter software over-current	<ol style="list-style-type: none"> 1. The fan motor system overloads; 2. The drive board fails; 3. The fan motor is not insulated well; 	<ol style="list-style-type: none"> 1. Change the fan motor; 2. Change the drive board; 3. Change the fan motor.
51	Out-of-step detection	<ol style="list-style-type: none"> 1.The wire is not connected well; 2.Bad drive board components; 3.The fan motor starting overloads; 4. The fan motor is demagnetized; 5. The fan motor is not insulated well. 	<ol style="list-style-type: none"> 1.Check the fan motor wire connection; 2.Change the drive board; 3. Change the fan motor. 4. Change the fan motor. 5. Change the fan motor.
52	Abnormal speed control	<ol style="list-style-type: none"> 1.Bad driver board components; 2.The fan motor shaft clamping; 3.The fan motor insulation fails. 	<ol style="list-style-type: none"> 1.Change the drive board; 2. Change the fan motor. 3.Change the fan motor.
53	Out of phase detection fault	<ol style="list-style-type: none"> 1. Phase loss of the fan motor; 2. Bad drive board components. 	<ol style="list-style-type: none"> 1. Change the drive board; 2. Change the fan motor; 3. Change the fan motor
54	IPM-FO hardware over-current (edge)	<ol style="list-style-type: none"> 1.The fan motor overloads or over-current; 2.The drive board fails; 3.The fan motor insulation fails. 	<ol style="list-style-type: none"> 1. Change the fan motor; 2. Change the drive board; 3. Change the fan motor
55	IPM-FO hardware over-current (level)	<ol style="list-style-type: none"> 1.The fan motor overloads or over-current; 2.The drive board fails; 3.The fan motor insulation fails. 	<ol style="list-style-type: none"> 1. Change the fan motor; 2. Change the drive board; 3. Change the fan motor
56	The fan motor -AD Offset abnormal detection fault	The drive board circuit fails.	Change the drive board.
57	IPM temperature overload fault	<ol style="list-style-type: none"> 1. The drive board fails; 2. Loosening of IPM and radiator; 3. The fan motor load is large; 	<ol style="list-style-type: none"> 1. Change the drive board; 2. Check if the IPM is in close contact with theradiator 3. Check whether the air inlet/outlet is seriously dirty.
58	The fan motor startup fault	<ol style="list-style-type: none"> 1. Poor fan motor wire contact; 2. The drive board fault. 	<ol style="list-style-type: none"> 1. Check the fan motor wire; 2. Change the drive board.
59	Inverter DC voltage of fan motor overload fault	<ol style="list-style-type: none"> 1. Power supply input is too high or too low; 2. The drive board fault. 	<ol style="list-style-type: none"> 1. Check the power supply; 2. Change the drive board.
60	Inverter DC low voltage of fan motor overload fault		
61	Communication failure.	<ol style="list-style-type: none"> 1. Communication wire connection is not proper; 2. Driver board fails; 3. Control board fails. 	<ol style="list-style-type: none"> 1. Check the wiring; 2. Change the driver board; 3. Change the control board.

Table 5 Analysis of the driving board fault (75K/85K)

Fault code	Fault description	Possible reasons for abnormality	How to deal with
1	Q axis current detection, failure in drive control	1. Compressor wire is not connected properly; 2. Bad driver board components; 3. Compressor start load is too large; 4. Compressor demagnetization; 5. The compressor is short of oil, and the crankshaft is worn seriously; 6. The compressor insulation fails.	1. Check the compressor wire; 2. Change the driver board ; 3. Turn on the unit after the pressure is balanced again; 4. Change the compressor; 5. Change the compressor; 6. Change the compressor.
2	Loss phase detection fault	1.Compressor voltage default phase; 2.Bad driver board components; 3.The compressor insulation fault.	1.Check the compressor wire connection; 2.Change the driver board; 3.Change the compressor.
3	Initialization, phase current imbalance	Bad driver board components.	Change the driver board .
4	Speed estimation, failure in drive control	1.Bad driver board components; 2.Compressor shaft is clamped; 3.The compressor insulation fails.	1.Change the driver board ; 2.Change the compressor ; 3.Change the compressor .
5	IPM FO output fault	1. System overload or current overloads. 2. Driver board fails; 3. The compressor is short of oil, and the crankshaft is worn seriously; 4. The compressor insulation fault.	1.Check the air conditioner system; 2.Change the driver board; 3.Change the compressor; 4.Change the compressor.
6	Communication between driver board and control board fault	1.Communication wire connection is not well; 2.Driver board fault; 3.Control board fault.	1. Check the compressor wire connect. 2. Change the driver board; 3. Change the control board ;
8	DC voltage, overload voltage	1. Supply voltage input is too high ; 2. Driver board fault;	1. Check the power supply; 2. Change the driver board;
13	Inverter over current	1. System overload, current is too large; 2. Driver board fault; 3. The compressor is short of oil, and the crankshaft is worn seriously; 4. The compressor insulation fault.	1. Check the system; 2. Change the driver board; 3. Change the compressor; 4. Change the compressor.
15	The instantaneous power off detection	1.The power supply is not stable ; 2.The instantaneous power failure ; 3.Driver board fault.	1. Check the power supply; 2. Not fault; 3. Change the driver board.
16	Low DC	1. Voltage input is too low; 2. Drive board fault.	1. Check the power supply; 2. Change the driver board.
22	IPM temperature overload fault	1. The drive board fails; 2. Loosening of IPM and radiator; 3. The fan motor load is large;	1. Change the drive board; 2. theradiator 3. Check whether the air inlet/outlet is seriously dirty.

Table 6 Limitation Code

Code	Definitions	Descriptions
101	When overcurrent occurs, stop the frequency from increasing.	Current control
102	When overcurrent occurs, reduce the frequency.	Current control
103	When the temperature of IPM module is too high, stop the frequency from increasing.	Frequency control to keep appropriate temperature of IPM module.
104	When the temperature of IPM module is too high, reduce the frequency.	Frequency control to keep appropriate temperature of IPM module.
105	When the discharge temperature is too high, stop the frequency from increasing.	Frequency control to keep appropriate discharge temperature.
106	When the discharge temperature is too high, reduce the frequency.	Frequency control to keep appropriate discharge temperature.
107	In cooling mode, when the temperature of the outdoor unit coil is too high, stop the frequency from increasing.	Frequency control to keep appropriate temperature of the outdoor unit coil in cooling mode.
108	In cooling mode, when the temperature of the outdoor unit coil is too high, reduce the frequency.	Frequency control to keep appropriate temperature of the outdoor unit coil in cooling mode.
113	To prevent the indoor unit from being frozen or high temperature, stop the frequency from increasing.	Frequency control to keep appropriate temperature of the indoor unit coil.
114	To prevent the indoor unit from being frozen or high temperature, reduce the frequency.	Frequency control to keep appropriate temperature of the indoor unit coil.
119	When DSH exceeds the target value, the valve opening gets wider to adjust the flow.	Control on expansion valve based on DSH.
120	When DSH exceeds the target value, the valve opening gets narrower to adjust the flow.	Control on expansion valve based on DSH.
121	When DSH exceeds the target value, stop the valve opening from getting narrower.	Control on expansion valve based on DSH.
122	When DSH exceeds the target value, stop the valve opening from getting wider.	Control on expansion valve based on DSH.
131	When the temperature of IPM module is too high, stop the frequency from increasing.	Frequency control to keep appropriate temperature of IPM module.
132	When the temperature of IPM module is too high, reduce the frequency.	Frequency control to keep appropriate temperature of IPM module.
134	When the discharge temperature is too high, stop the valve opening getting narrower.	Control on discharge temperature expansion valve.
140	The compressor overloads.	Control on the compressor output.
141	The compressor current overloads.	Control on the output torque of the compressor.

※ DSH: Discharge Super Heat

These codes appearing in the operation process indicate some kind of normal operation state, instead of faults, so they do not need to be dealt with.

17. Checking components

17.1 Check refrigerant system

TEST SYSTEM FLOW

Conditions: ① Compressor is running.
 ② The air condition should be installed in good ventilation.

Tool: Pressure Gauge

Technique: ① see ② feel ③ test

- See ----- Tube defrost.
- Feel ----- The difference between tube's temperature.
- Test ----- Test pressure.

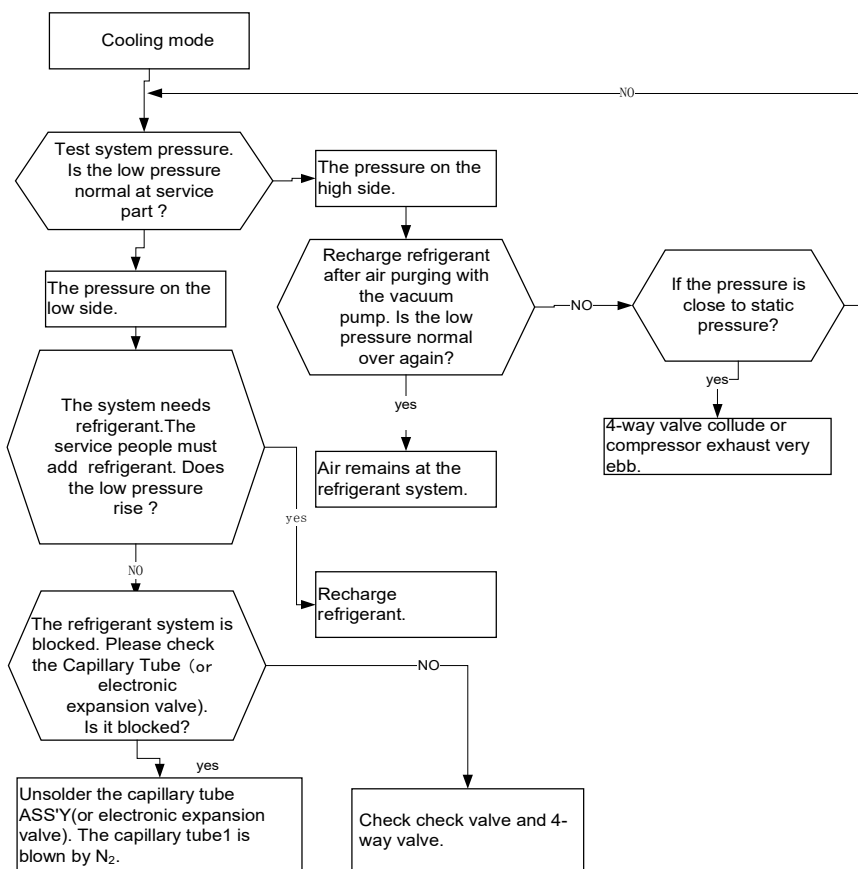
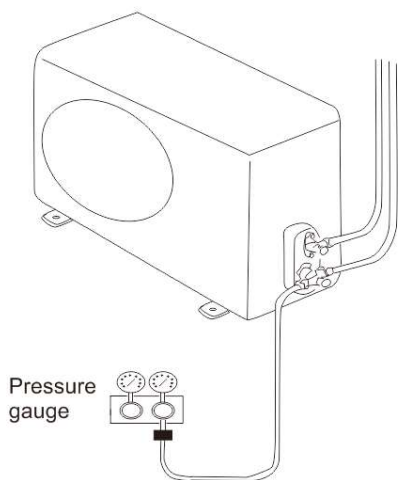

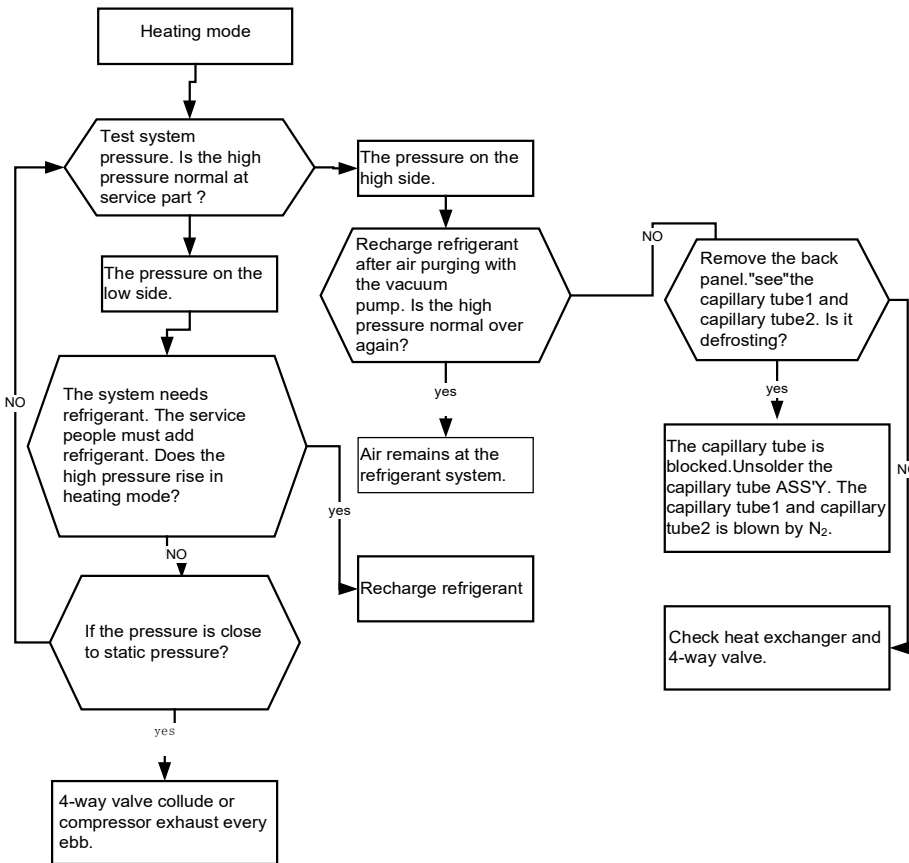

17.2 Check parts unit

1. Indoor unit fan motor

Duct/Cassette type

Duct:

75K/85K DC Motor model: ZW702D000015

Compact Cassette:

14K/18K DC Motor model: ZW465B500021

Cassette:

14K~24K DC Motor model: ZW511B500061

36K~48K DC Motor model: ZW511B500062

Floor ceiling type

42K/48K DC motor model:

SIC-70CW-F1100-6

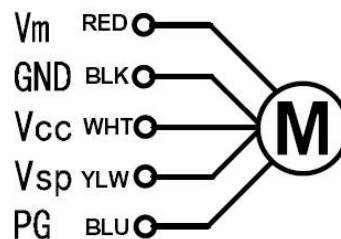
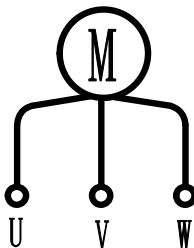

2. Outdoor unit fan motor(DC type)

14K~18K model: ZW511A800002

21K~24K model: ZKFN-102-8-1

36K~48K model: ZW511A800002 + ZW511A800052

75K~85K model:

SIC-88FWJ-F1200-2

SIC-88FWJ-F1200-3

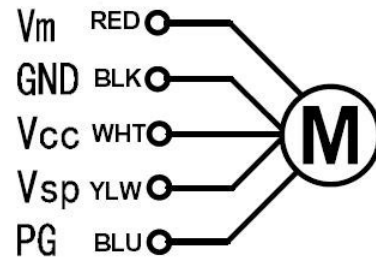
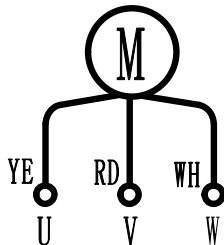

Test in resistance(For AC motor)

TOOL: Multimeter.

Test the resistance of the main winding. The indoor fan motor is fault if the resistance of main winding 0(short circuit)or ∞ (open circuit) .

Test in voltage(For DC motor)

TOOL: Multimeter.

Insert screwdriver to rotate indoor fan motor slowly for 1 revolution or over, and measure voltage “YELLOW” and “GND” on motor. The voltage repeat 0V DC and 5V DC. NOTE: Please don't hold motor by lead wires.

Please don't plug IN/OUT the motor connector while power ON.

Please don't drop hurl or dump motor against hard material. Malfunction may not be observed at early stage after such shock. But it may be found later, this type of mishandling void our warranty.

3. Compressor

Compressor examine and repair

14K/18K: KTN150D42UFZ

21K/24K: KTM240D57UMT

36K: KTF310D43UMT

42K/48K: KTF400D64UMT

75K/85K: KTQ580D66UNT

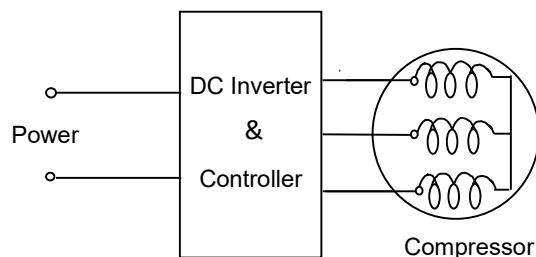

Test in resistance.

TOOL: Multi-meter.

Test the resistance of the winding. The compressor fails if the resistance of winding is 0 (short circuit) or ∞ (open circuit).

Familiar error:

- 1) Compressor motor lock.
- 2) Discharge pressure value approaches static pressure value.
- 3) Compressor motor winding abnormality.

Notes:

- 1) Don't put a compressor on its side or turn over.
- 2) Please assemble the compressor in your air conditioner rapidly after removing the plugs.
Don't place the comp. in air for a long time.
- 3) Avoid compressor running in reverse caused by connecting electrical wire incorrectly.
- 4) Warning! In case AC voltage is impressed to compressor, the compressor performance will decrease because of its rotor magnetic force decreasing.

5. Step motor

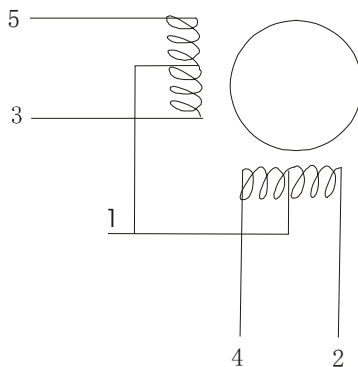

Test in resistance.

TOOL: Multimeter.

Test the resistance of winding. The stepper motor fails if the resistance of winding is 0 (short circuit) or ∞ (open circuit).

6. Fuse

Check for continuity of fuse on PCB ASS'Y.

Remove the PCB ASS'Y from the electrical component box. Then pull out the fuse from the PCB ASS'Y. Check for continuity by a multimeter as shown below.

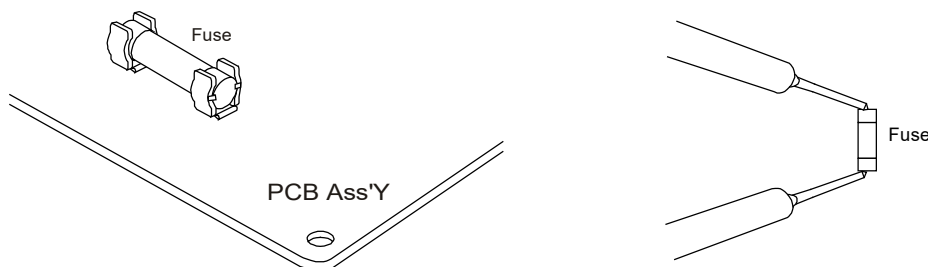



Hisense



EXCLUSIEF IMPORTEUR VAN HISENSE BENELUX

Carneool 400
3316 KC Dordrecht
Nederland

Tel.: +31 (0) 88 4 35 54 50
E-Mail: info@hs-cs.nl

Truibroek 94 | unit 11
3945 Ham
België

Tel.: +32 (0) 11 46 04 46
E-Mail: info@hs-cs.be